

- 1
- 2
- 3
- 4
- 5
- 6
- 7
- 8
- 9
- 10
- 11
- 12
- 13
- 14
- 15
- 16
- 17
- 18

SPECIFICATION

Stainless steel **NI**
AISI 303

Spherical washer
AISI 303 stainless steel

Cylindrical-head screw
Stainless Steel AISI 304

Washer
Stainless Steel AISI 304

FEATURES AND APPLICATIONS

GN 355.2 levelling elements are used to realise the levelling between two plates on machines, equipment etc., not on the same plane.

They consist of a levelling screw, a socket cap screw with disk and a spherical washer. The levelling screw and spherical washer are connected together.

The external diameter of the spherical washer d_4 is smaller than the thread core diameter d_1 , thereby also making mounting possible when the seating is inaccessible.

After making the adjustment using the assembly tools GN 355.1 available as an accessory, the screw is tightened firmly causing the levelling screw and the spherical washer to spread and is secured in this way against twisting in the threaded hole.

The values of w and x shown in the table, and those related to the static load have to be considered as reference values, which may differ depending on the type of application. In general, they do not constitute a warranty of condition. The user must determine whether the product is suitable for the intended purpose.

ACCESSORY ON REQUEST

Assembly tools GN 355.1 (Code no. see table)



Application example

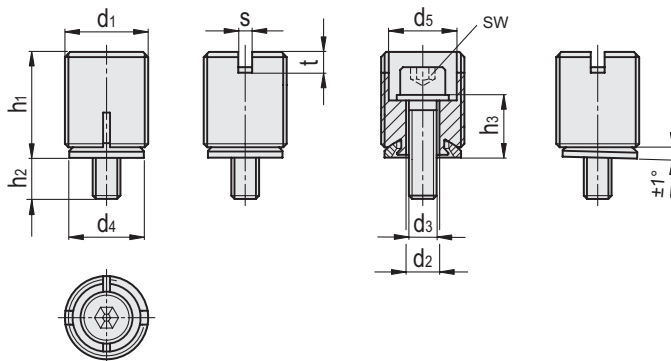
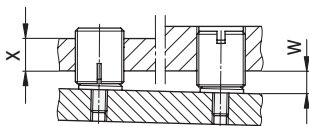

Code	Description	d1	d2	d3	d4	d5	h1	h2	h3	sw	t	s	w	x	Static load [N]	Assembly tool	⚖️
GN.21371	GN 355.2-M12X1-4.5-NI	M12X1	4.5	M4	10.5	9.1	19.4	10.6	9.4	3	3	2	8	8	4400	GN 355.1-12	12
GN.21373	GN 355.2-M18X1-7-NI	M18X1	7	M6	16	12.6	27.3	9.6	15.4	5	3	2	13	12	1000	GN 355.1-18	38
GN.21375	GN 355.2-M24X1.5-9-NI	M24X1.5	9	M8	21.5	19.6	30.1	12.3	17.7	6	6	4	16	16	2700	GN 355.1-24	68